

LIGHT SKY®

FLY DRAGON LIGHTING EQUIPMENT CO.,LTD

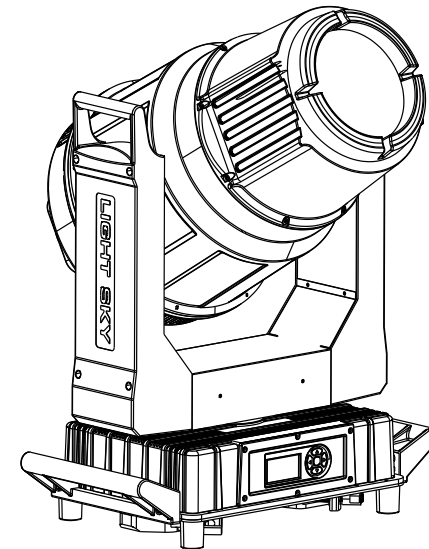

LIGHT SKY®

Tel:0086-20-61828288

Fax:0086-20-61828188 Pc:510800

Web:www.lightsky.com.cn

E-mail: flydragon@lightsky.com.cn

asia@lightsky.com.cn

india@lightsky.com.cn

europa@lightsky.com.cn

latinamerica@lightsky.com.cn

middle-east@lightsky.com.cn

american@lightsky.com.cn

Address: No. 43, Yunfeng Road, Xiuquan Street,
Huadu District, Guangzhou, China



LIGHT SKY®



SHARK400BSW

USER MANUAL

Please read these user manual carefully before use!

CHANNEL FUNCTION(V1.0)

Channel	DMX		Percentage	Function
1	0-255	0-100	Pan	
2	0-255	0-100	Pan Fine	
3	0-255	0-100	Tilt	
4	0-255	0-100	Tilt fine	
5			Function	
	0-9		Reserved (0=default)	
	10-14		Reserved	
	15-19		Reserved	
	20-24		Reserved	
	25-29		Reserved	
	30-34		Reserved	
	35-39		Reserved	
	40-44		Reserved	
	45-49		Reserved	
	50-54		Reserved	
	55-59		Reserved	
	60-64		Reserved	
	65-69		Reserved	
	70-74		Reserved	
	75-79		Reserved	
	80-84		Reserved	
	85-89		Reserved	
	90-94		Reserved	
	95-99		Reserved	
	100-101		Reserved	
	102-103		Reserved	
	104-105		Reserved	
	106-107		Reserved	
108-119		Reserved		
120-124		Reserved		
125-129		Reserved		
130 - 139		Lamp On		
140 - 149		Pan/Tilt reset		
150 - 159		Colour system reset		
160 - 169		Gobo wheels reset		
170 - 179		Dimmer/Shutter reset		
180 - 189		Zoom/focus/frost/prism wheels reset		
190 - 199		Effect wheel reset		
200 - 209		Total reset		
210 - 229		Reserved		
230 - 239		Lamp Off		
240 - 244		Reserved		
245 - 249		Reserved		
250 - 255		Reserved		
6			Dimmer intensity	
	0 - 255		Dimmer intensity from 0% to 100% (0=default)	
7			Shutter/ strobe	
	0 - 31		Shutter closed	
	32 - 63		Shutter open (32=default)	
	64 - 95		Strobe-effect from slow to fast	
	96 - 127		Shutter open	
	128 - 143		Opening pulse in sequences from slow to fast	

Channel	DMX	Percentage	Function
	144 - 159	Closing pulse in sequences from fast to slow	
	160 - 191	Shutter open	
	192 - 223	Random strobe-effect from slow to fast	
	224 - 255	Shutter open, Full lamp power	
8		Cyan	
	0 - 255	Cyan from min. saturation --> full cyan (0=default)	
9		Magenta	
	0 - 255	Magenta from min. saturation --> full magenta (0=default)	
10		Yellow	
	0 - 255	Yellow from min. saturation --> full yellow (0=default)	
11		Colour wheel	
		Continual positioning	
	0-4	White	
	5-8	White+Red	
	9-12	Red	
	13-16	Red+Orange	
	17-20	Orange	
	21-24	Orange+Aquamarine	
	25-28	Aquamarine	
	29-32	Aquamarine+Green	
	33-36	Green	
	37-40	Green+Light Green	
	41-44	Light Green	
	45-48	Light Green+Lavender	
	49-52	Lavender	
	53-56	Lavender+Pink	
	57-60	Pink	
	61-64	Pink+Yellow	
	65-68	Yellow	
	69-72	Yellow+Magenta	
	73-76	Magenta	
	77-80	Magenta+Cyan	
	81-84	Cyan	
	85-88	Cyan+CTO 260	
	89-92	CTO 260/CTO2	
	93-96	CTO 260+CTO 190/CTO2+CTO1	
	97-100	CTO 190/CTO1	
	101-104	CTO 190+CTB 8000/CTO1+CTB	
	105-108	CTB 8000/CTB	
	109-112	CTB 8000+Blue	
	113-116	Blue	
	117-120	Blue+White	
121 - 181	Forwards rainbow effect from fast to slow		
182 - 188	No rotation		
189 - 249	Backwards rainbow effect from slow to fast		
250 - 255	Auto random colour selection from fast to slow		
		Static gobo wheel	
	0-3	White	

Channel	DMX	Percentage	Function
12	4-7	Gobo1	
	8-11	Gobo2	
	12-15	Gobo3	
	16-19	Gobo4	
	20-23	Gobo5	
	24-27	Gobo6	
	28-31	Gobo7	
	32-35	Gobo8	
	36-39	Gobo9	
	40-43	Gobo10	
	44-47	Gobo11	
		<i>Shaking gobos from slow to fast</i>	
	48-60	Gobo1 Shake Slow-Fast Speed	
	61-73	Gobo2 Shake Slow-Fast Speed	
	74-86	Gobo3 Shake Slow-Fast Speed	
	87-99	Gobo4 Shake Slow-Fast Speed	
	100-112	Gobo5 Shake Slow-Fast Speed	
	113-125	Gobo6 Shake Slow-Fast Speed	
	126-138	Gobo7 Shake Slow-Fast Speed	
	139-151	Gobo8 Shake Slow-Fast Speed	
	152-164	Gobo9 Shake Slow-Fast Speed	
	165-177	Gobo10 Shake Slow-Fast Speed	
	178-190	Gobo11 Shake Slow-Fast Speed	
	191-207	Effect Shake Slow-Fast Speed	
	208-226	Forwards gobo wheel rotation from fast to slow	
227-230	No rotation		
231-249	Backwards gobo wheel rotation from slow to fast		
250-255	Auto random gobo selection from fast to slow		
13		Rotating gobo wheel	
		/Index - set indexing on channel 14	
	0	Open/Hole (0=default)	
	1-8	Hole (flat field)	
	9-21	Gobo 1	
	22-34	Gobo 2	
	35-47	Gobo 3	
	48-60	Gobo 4	
	61-73	Gobo 5	
	74-86	Gobo 6	
	87-99	Gobo 7	
	100-112	Gobo 8	
		<i>Shaking gobo from slow to fast</i>	
		Index - set indexing on channel 14	
	113-125	Gobo 1	
	126-138	Gobo 2	
	139-151	Gobo 3	
	152-164	Gobo 4	
	165-177	Gobo 5	
	178-190	Gobo 6	
191-203	Gobo 7		
204-216	Gobo 8		
217-249	Open/hole		

Channel	DMX	Percentage	Function
	250-255	Auto random gobo selection from fast to slow	
14		Rot. gobo indexing and rotation	
	0 - 127	Gobo indexing	
	128 - 187	Forwards gobo rotation from fast to slow	
	188-195	No rotation	
	196 - 255	Backwards gobo rotation from slow to fast	
15		Prism wheel 1	
		This wheel is blocked If Rotating gobo wheel >0 DMX	
	0-3	Open position/hole (0=default)	
		Index - set indexing on channel 16	
	4-15	Prism 3 - 6-facet linear	
	16-27	Prism 2 - 4-facet 12° circular	
	28-39	Prism 1 - 8-facet 12° circular	
		Rotation - set rotation on channel 16	
	40-51	Prism 3 - 6-facet linear	
	52-63	Prism 2 - cylindrical	
64-75	Prism 1 - 8-facet 12° circular		
76-255	Raw DMX		
16		Prism wheel 1 indexing/rotation	
		Prism indexing - set position on channel 15	
	0 - 255	Prism 1 indexing	
		Prism 1 rotation - set position on channel 15	
	0-3	No rotation	
	4-34	Slow → Fast, 90° Rotating back and forth	
	35-65	Slow → Fast, 180° Rotating back and forth	
	66-96	Slow → Fast, 270° Rotating back and forth	
	97-127	Slow → Fast, 360° Rotating back and forth	
	128-188	Forwards prism rotation from fast to slow	
189-194	No rotation (128=default)		
195-255	Backwards prism rotation from slow to fast		
17		Prism wheel 2	
	0-3	Open position/hole (0=default)	
		Index - set indexing on channel 18	
	4-15	Prism - 8-facet 18° circular	
		Rotation - set rotation on channel	
	16-27	Prism - 8-facet 18° circular	
28-255	Raw DMX		
18		Prism wheel 2 indexing/rotation	
		Prism indexing - set position on channel 17	
	0-255	Prism indexing	
		Prism rotation-set position on channel 17	
	0	No rotation	
	4-34	Slow → Fast, 90° Rotating back and forth	
	35-65	Slow → Fast, 180° Rotating back and forth	
	66-96	Slow → Fast, 270° Rotating back and forth	
97-127	Slow → Fast, 360° Rotating back and forth		

Channel	DMX	Percentage	Function
	128-188	Forwards prism rotation from fast to slow	
	189-194	No rotation (128=default)	
	195-255	Backwards prism rotation from slow to fast	
19		Pattern selection	
	0-3	Open position/hole (0=default)	
		Index - set indexing on channel 20	
	4-14	Prism macro Index 1	
	15-25	Prism macro Index 2	
	26-36	Prism macro Index 3	
	37-47	Prism macro Index 4	
	48-58	Prism macro Index 5	
	59-69	Prism macro Index 6	
	70-80	Prism macro Index 7	
		Rotation - set rotation on channel 20	
	81-91	Prism macro rotation 1	
	92-102	Prism macro rotation 2	
	103-113	Prism macro rotation 3	
	114-124	Prism macro rotation 4	
	125-135	Prism macro rotation 5	
	136-146	Prism macro rotation 6	
	147-157	Prism macro rotation 7	
	158-168	Prism macro rotation 8	
169-179	Prism macro rotation 9		
180-190	Prism macro rotation 10		
191-255	Raw DMX		
20		Pattern rotation and indexing	
		The channels are blocked: Prism Wheel 1/2, Prism Wheel 1/2 rot.	
		Pattern indexing - set position on channel 19	
	0 - 255	Pattern indexing	
		Pattern rotation - set position on channel 19	
	0	No rotation	
	1-127	Forwards pattern rotation from fast to slow	
	128	No rotation (128=default)	
	129-255	Backwards pattern rotation from slow to fast	
21		Frost	
	0-19	Open (0=default)	
	20-128	100% Light Frost	
	129-169	Pulse closing from slow to fast	
	170-210	Pulse opening from fast to slow	
	211-255	Ramping from fast to slow	
22		Zoom	
	0 - 255	Zoom from max. to min.beam angle (128=default)	
23		Zoom - fine	
	0 - 255	Fine zooming (0=default)	
24		Focus	
	0 - 255	Continuous adjustment from far to near (128=default)	
25		Focus Fine	
	0 - 255	Fine focusing (0=default)	

Channel	DMX	Percentage	Function
26		Focus2 AutoFocus on channel 27	
	0-255	AutoFocus	
27		Autofocus (priority & distance selection)	
		Select desired distance and effect on which you need to focus and use "Focus2" channel (26) to focus the image.	
	0-15	Autofocus Off	
	16-55	10 metres	
	56-95	15 metres	
	96-135	20 metres	
	136-175	30 metres	
	176-215	40 metres	
216-255	50 metres		
28		Effect Macro	
	0-15	Reserved	
	16-25	Effect 1	
	26-35	Effect 2	
	36-45	Reserved	
	46-55	Reserved	
	56-65	Reserved	
	66-75	Reserved	
	76-85	Reserved	
	86-95	Reserved	
	96-105	Reserved	
	106-115	Reserved	
	116-125	Reserved	
	126-135	Reserved	
	136-145	Reserved	
	146-155	Reserved	
	156-165	Reserved	
	166-175	Reserved	
	176-185	Reserved	
	186-195	Reserved	
196-205	Reserved		
206-215	Reserved		
216-225	Reserved		
226-235	Reserved		
	236-245	Reserved	
	246-255	Reserved	